

LABGARD^{ES}

NU-677 CLASS II TYPE A2 ANIMAL HANDLING BIOLOGICAL SAFETY CABINET



LABGARD NU-677 CLASS II TYPE A2  BIOLOGICAL SAFETY CABINET / CAGE CHANGING STATION



NuAire, Inc. | 2100 Fernbrook Lane | Plymouth, MN 55447 | U.S.A. | 763.553.1270 | WWW.NUAIRE.COM



NU-677

LabGard ES NU-677

The NuAire LabGard ES (Energy Saver) model NU-677 Class II Type A2 Biological Safety Cabinet / Cage Changing Station is NSF listed to provide personnel, product, and environmental protection for sensitive animal handling and cage changing procedures.

LabGard Class II Biological Safety Cabinets can be either exhausted back into the room or connected to a facility HVAC system. 30% of the cabinet's airflow is exhausted and 70% is recirculated, minimizing cross-contamination of low to moderate risk biologicals in the absence of volatile toxic chemicals.

Performance

Energy Saver DC ECM Eon™ Motor

Save up to 40% on your total cost of ownership compared to previously used motor technologies. ECM motor technology utilizes less energy while containing more torque to extend the lives of your filters. ECM motors produce less heat, reducing the strain on your facilities HVAC system, as well as operating at a lower dbA level with less vibration creating a healthy environment for your research animals.

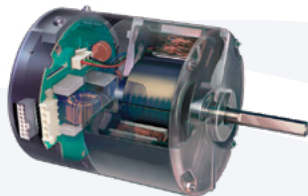

Increase the Life of the HEPA Filter

The costs associated with filter changes can add up quickly. Selecting a properly sized motor, fan, and HEPA filter(s), can allow a NuAire Biological Safety Cabinet to handle a 300% minimum increase in filter loading without reducing total air delivery by more than 10%. The addition of an internal exhaust damper and motor speed control can extend the life of your filters to ±10 years in an average vivarium setting.*

NSF Listed



The LabGard™ Biological Safety Cabinet provides biological containment protection for both the operator and product as defined by standard NSF/ANSI 49, and routinely validated by NuAire.

Unique Features Offer Workflow Flexibility



Feed Hoppers

Optional Feed hoppers allow technicians to easily access a food source within a sterile work zone. Up to 2 feed hoppers can be added on each side wall (total of 4) allowing the user to create a workflow utilizing one food source, or to segment up to 4 different diets.



Deep Wells

Optional deep wells can be added to stack clean or dirty cages inside a sterile work zone. Deep wells work well with the Innovive Disposable Caging System.



Waste Disposal System

Optional Waste Disposal System located within the work zone lets technicians dump bedding and waste while maintaining NSF/ANSI 49 Class II conditions.

Built-in Pass Through / Dirty Cage Collection

Optional Pass Through can allow technicians stack dirty cages outside of the work zone into a biohazard bag or can be built to connect to a glove box or even built into a wall for room to room transfers.



Ergonomics

The LabGuard NU-677 is ergonomically designed for maximum user comfort and adjustability to meet the requirements of the Americans with Disabilities Act (ADA).

Height Adjustable [A]

The LabGuard NU-677 offers an adjustable height range of 18 1/2" (470 mm), working height from 24 1/2" to 43" (622 to 1092 mm).

Large Access Opening [B]

The adjustable user access accommodates both rat and mouse cages, with an optimum 12" (305 mm) working height.

Improved Visibility

Incorporating cool white lighting and a frameless polished edge window, the NU-677 allows for greater visibility and better sight lines, reducing glare and causing less eye strain.

Prop Up Work Tray [C]

Assisting in routine cleaning, the work surface can be propped up allowing a technician to clean under the work surface. A drain valve is standard beneath the work tray.

Mobility [D]

5-inch (127mm) heavy-duty lockable castors allow the LabGuard Biosafety Cabinet to freely move within the animal facility, and to be easily transportable through a standard 36" (914mm) door.

More Useable Work Space [E]

NuAire's cabinets provide the largest effective work zone, reducing arm/neck/shoulder strain. NuAire provides up to 37% more useable work space compared to competitive models**

Quiet

Maximum of 67 dbA with a background level of 57 dbA.



[A]



[B]



[C]



[D]



[E]

Construction

Monolithic Pressure Tight Design

Constructed of 16 gauge type 304 stainless steel, the LabGard Biosafety Cabinet is designed for heavy use and long term usability. In fact, some of NuAire's original cabinets built in the 1970's are known to still be in use.

Animal Hair / Dander Pre-filter

A pre-filter located in the back wall of the cabinet has been positioned to capture bedding, hair, and dander particles to extend the life of your HEPA filters. [F] The pre-filter is secured by four thumb screws and is easily removed cleaning or reuse.

Thinner Profile

The NU-677 is designed to minimize space requirements, a space savings up to 20% versus competitive units.**

Technology

The **FLOWGARD** touchpad monitors pressure inside the plenum and alarms if the pressure goes out of set range.



nitecare Night Setback

Save money when running your cabinet 24 / 7. Initiated by closure of the window, the blower motor will reduce operational airflow to the minimum required to conserve energy while maintaining a sterile work zone.

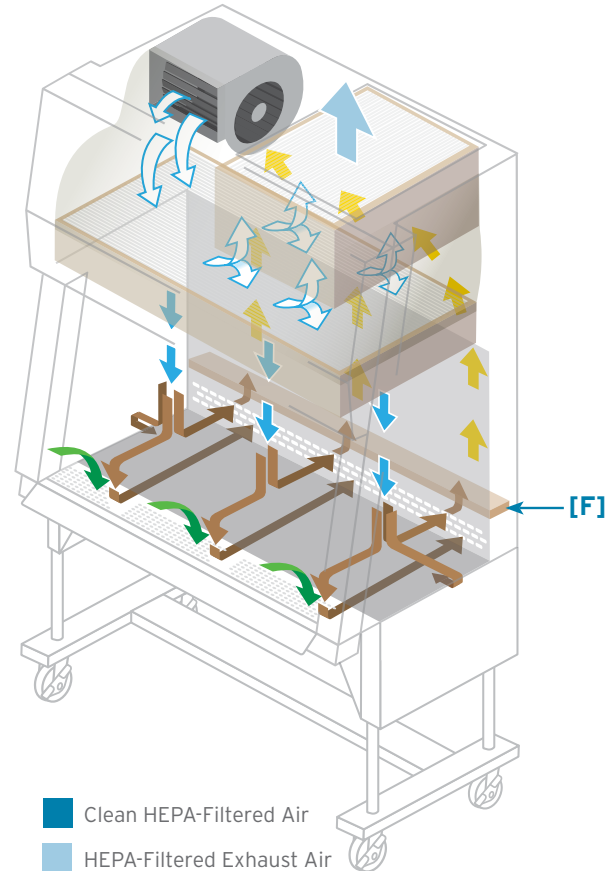

- Clean HEPA-Filtered Air
- HEPA-Filtered Exhaust Air
- Mixed Inflow & Recirculated Air
- Room Air Inflow
- Pre-filtered Contaminated Air
- Contaminated Worksurface Air

**Calculations are based on a volume differential. Unit measurements have been taken from competitors purchase specifications and calculated by NuAire.

Safety

dynamic air barrier

An aerodynamic air foil pulls air into the front grill at a velocity of 105 fpm (0.53 m/s) [G], isolating the work area from the surrounding environment while protecting the user.



true laminar

The combination of ECM motor technology and HEPEX™ Zero Leak Airflow System produce uniform pressure over the surface of the supply HEPA filter, producing a constant and uniform airflow across the work surface at 60 fpm (0.30 m/s). [H]

HEPEX zero-leak airflow

All contaminated ducts, plenums, and gaskets are under negative pressure or surrounded by negative pressure to eliminate the possibility of cabinet or gasket leaks and to guard against HEPA failure. [I]

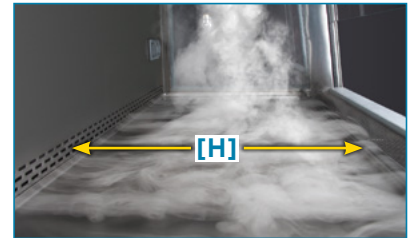

Password Protection

A security password can be set to lock cabinet settings.

Additional Options / Accessories

- Dual or Single Feed Hopper(s)
- Ultraviolet Light
- GFI Outlets (2 Standard)
- Additional Outlets
- Additional Service Valves for Gas, Air, Vac
- Pull-Out Storage Trays
- Variable Airflow Exhaust Transition
- Stainless Steel Armrest
- Framed Window Sash

Notes:

- 5 Year Warranty Standard for Parts and Labor (US & CA)
- 6 Year Warranty Standard for Parts (INTL)



This brochure is intended for general descriptive and informational purposes only. It is subject to change and does not constitute an offer, representation or warranty (express or implied) by NuAire, Inc. Interested parties should confirm the accuracy of any information in this brochure as it relates to NuAire Laboratory Equipment directly with NuAire, Inc., before relying on it to make a purchase decision. NuAire, Inc., reserves the right to make changes, at any time, without prior notice, in prices, colors, materials, equipment, specifications, and models and to discontinue models or equipment. Due to continuous product development and other pre- and post-production factors, actual equipment, materials and specifications may vary from this brochure. Some equipment shown with optional equipment. Availability and delivery times for particular models or equipment may vary. Specifications, options and accessories may differ in other countries. For additional information on availability, options or accessories, see your NuAire Sales Representative or contact NuAire, Inc.

Specifications

Catalog Number	NU-677-400 Nominal 4 foot (1.2m)	NU-677-500 Nominal 5 foot (1.5m)	NU-677-600 Nominal 6 foot (1.8m)
Performance Specifications	NSF/ANSI 49		
NSF Std. No. 49 Class	Class II, Type A2		
Style of Cabinet	Bench top/console with basestand		
Cabinet Construction	All welded stainless steel 16GA, Type 304 pressure tight design		
Diffuser for Air Supply (Metal)	Non-flammable		
HEPA Filter Seal Type: Supply Filter-99.99% - Eff. on 0.3 microns Exhaust Filter-99.99% - Eff. on 0.3 microns	HEPEX Seal, Neoprene, Spring-loaded		
Fumigation (per NIH/NSF Procedure):	Yes		
Standard Services (Duplex Outlet):	Two, Backwall		
Optional Services: Gas Cocks $\frac{3}{8}$ " NPT Ultraviolet Light	Up to 3 Each Side wall, One Back wall		
Cabinet Size Inches (mm):			
Height Maximum	97 $\frac{1}{2}$ (2477)	97 $\frac{1}{2}$ (2477)	97 $\frac{1}{2}$ (2477)
Height Minimum	79 (2007)	79 (2007)	79 (2007)
Width	53 $\frac{5}{8}$ (1362)	65 $\frac{5}{8}$ (1667)	77 $\frac{5}{8}$ (1972)
Depth (with Control Center & Armrest)	32 $\frac{3}{4}$ (832)	32 $\frac{3}{4}$ (832)	32 $\frac{3}{4}$ (832)
Work Access Opening Inches (mm):			
Standard Opening	12 (305)	12 (305)	12 (305)
Standard Inflow Velocity	105 FPM (.53 m/s)	105 FPM (.53 m/s)	105 FPM (.53 m/s)
Work surface Height Min/Max	24 $\frac{1}{2}$ (662) / 43 (1092)	24 $\frac{1}{2}$ (662) / 43 (1092)	24 $\frac{1}{2}$ (662) / 43 (1092)
Work Zone Inches (mm):			
Height	28 (711)	28 (711)	28 (711)
Width	46 $\frac{3}{8}$ (1178)	58 $\frac{3}{8}$ (1483)	70 $\frac{3}{8}$ (1788)
Depth	25 (635)	25 (635)	25 (635)
Viewing Window (Tempered Sliding Glass) Inches (mm):	Fully Closed to 20 (508) Open		
Light Intensity on Work Surface:	90 - 120 lm/ft ² (968 - 1291 Lux)		
Required Exhaust CFM/CMH (Standard/Optional):			
Variable Flow Canopy (NU-911)	486 / 656 (626 / 1115)	611 / 761 (1038 / 1293)	758 / 868 (1288 / 1475)
Fixed Flow Canopy (NU-907)	526 (894)	651 (1106)	796 (1352)
Plant Duct Static Pressure:	Minimum 0.05 in. (1.27 mm) Maximum 0.2 in (5.08 mm)		
Sound Level:	67 dbA		
Heat Rejected , BTU, Per Hour, Non-vented / Vented:	2551 / 157		
Electrical:	115V / 60 Hz E: 230V / 50-60Hz		
Energy Usage:	275 W	425 W	445 W
Crated Shipping Weight *:	800 lbs. / 362 kg.	865 lbs. / 392 kg.	930 lbs. / 421 kg.
Net Weight	750 lbs. / 340 kg.	815 lbs. / 369 kg.	880 lbs. / 398 kg.

* Crated shipping weight does not include weight for accessories or options.



For more information please visit
www.nuaire.com or call **1.800.328.3352**



Your NuAire Partner: