

REV	CO	DESCRIPTION	DATE	DFTM	CHKD
C	000098	ADDED CORD PASS-THRU	9/6/2019	TH	DSH

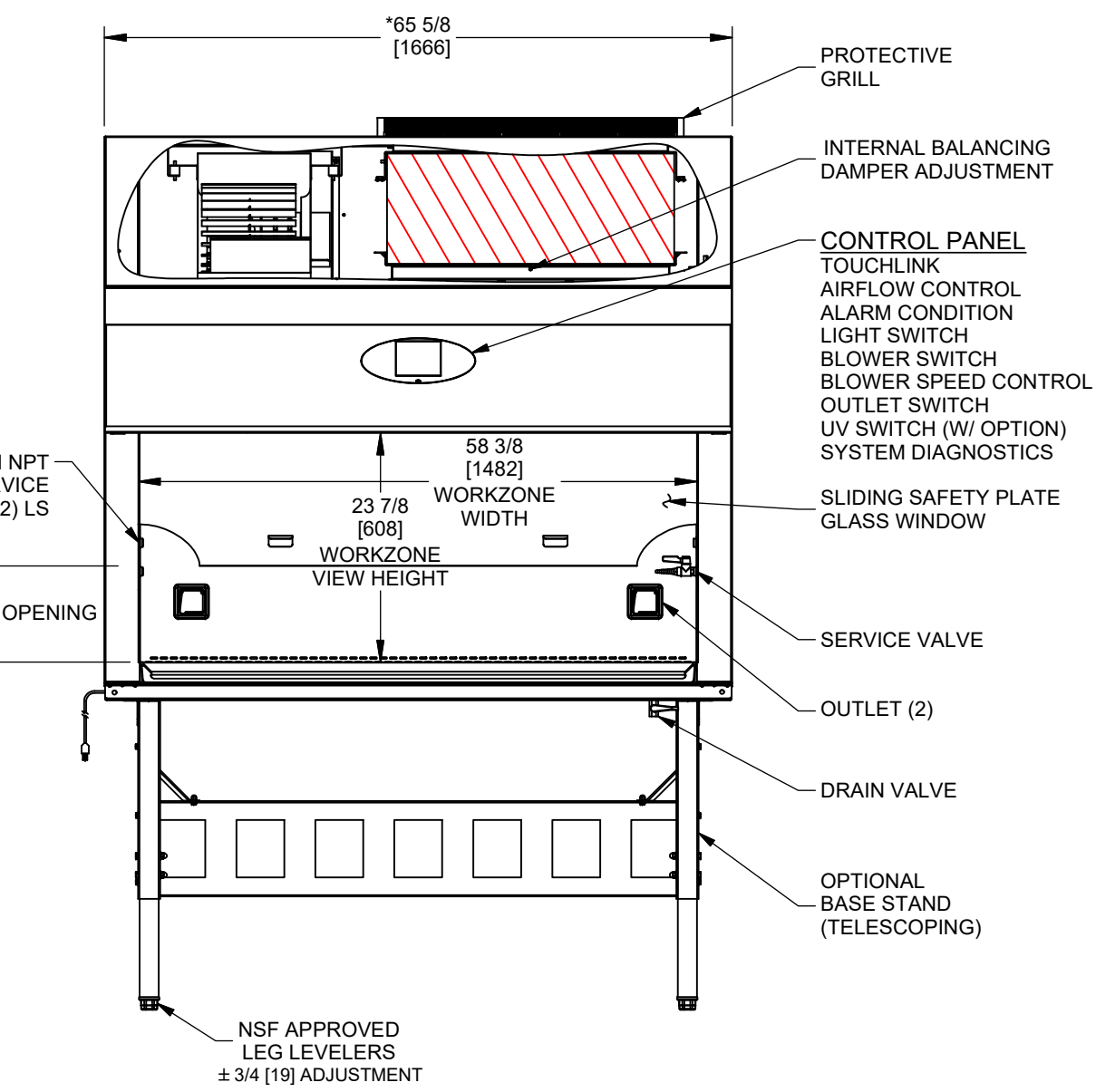
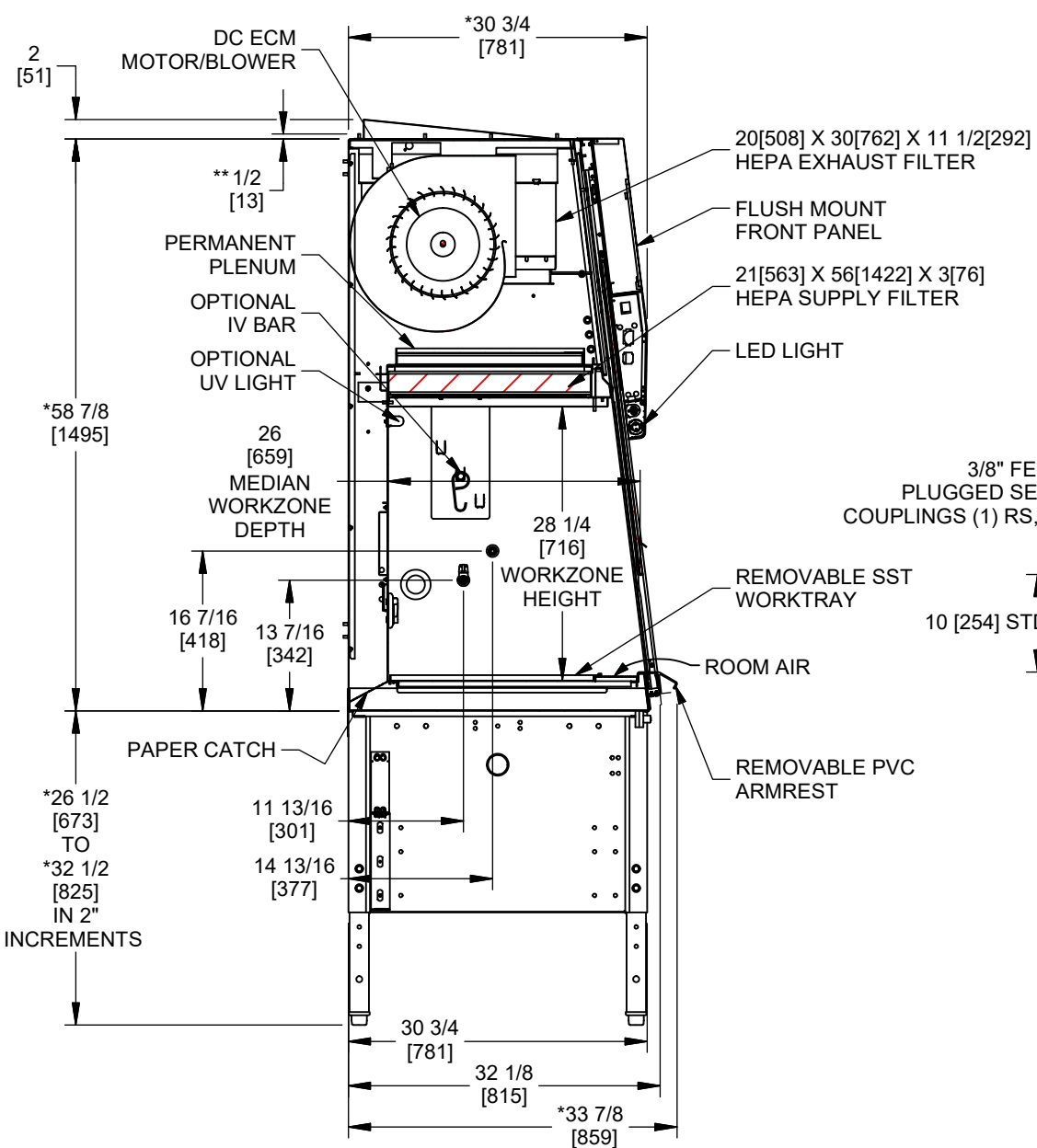
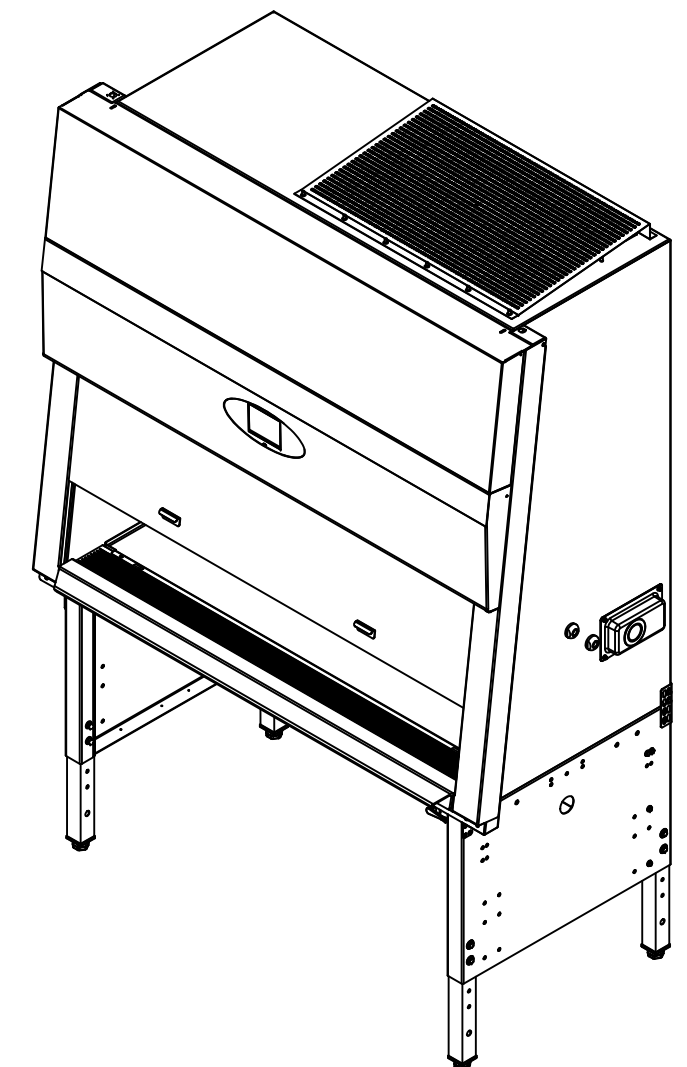
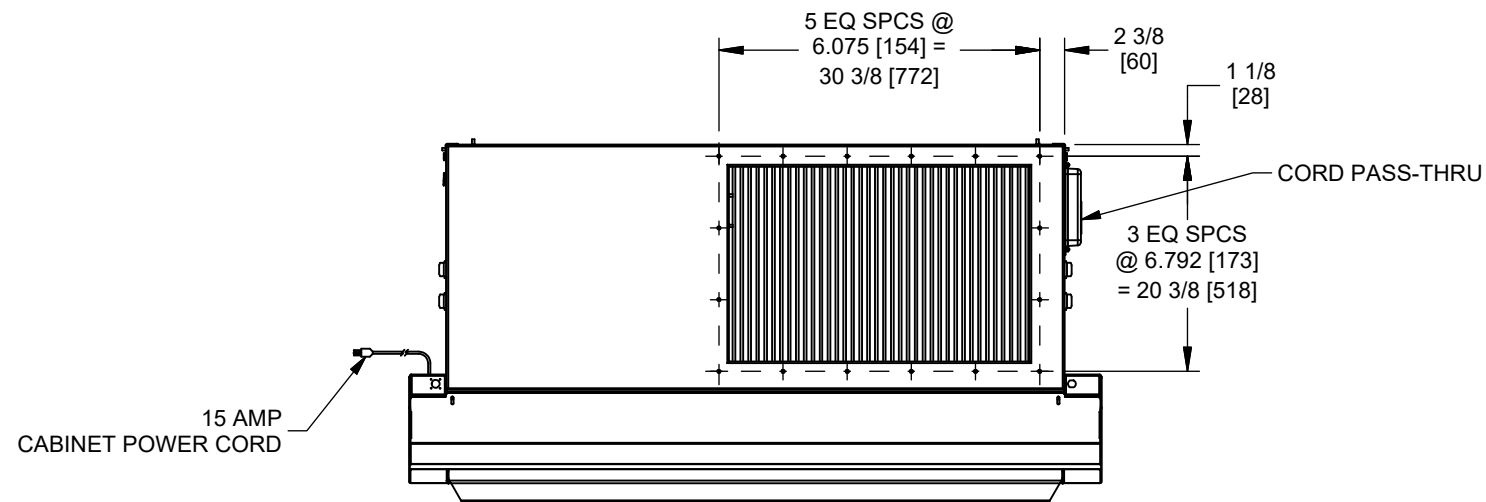

* OVERALL DIMENSIONAL TOLERANCE ±1/4 [6.35]
ALL OTHER DIMENSIONS ±1/8 [3.17]

TITLE NU-545-500E Class II Type A2 Biosafety Cabinet					
DFTM JK	DATE 4/4/2016	CHKD DSH	SHEET 1	OF 1	
DRAWING NUMBER		BCD-18247			C

** ADD 1/2" [13] TO OVERALL HEIGHT WITH PROTECTIVE GRILL REMOVED

INCH MILLIMETER