

REV	CO	DESCRIPTION	DATE	DFTM	CHKD
D	000059	UPDATED, ADDED CORD PASS-THRU	8/29/2019	TH	DSH

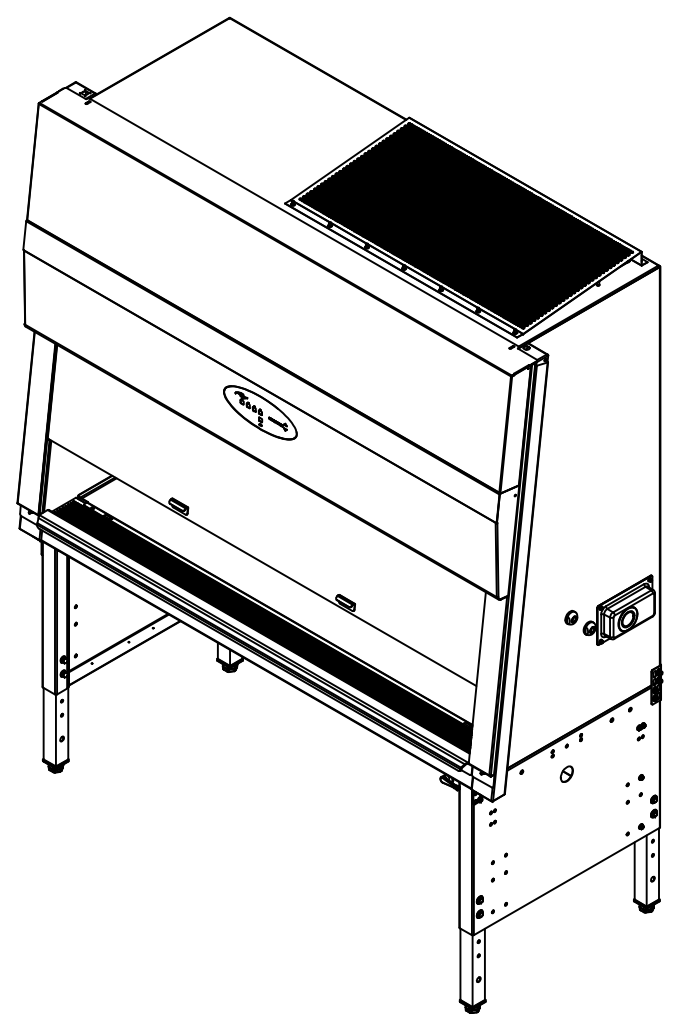
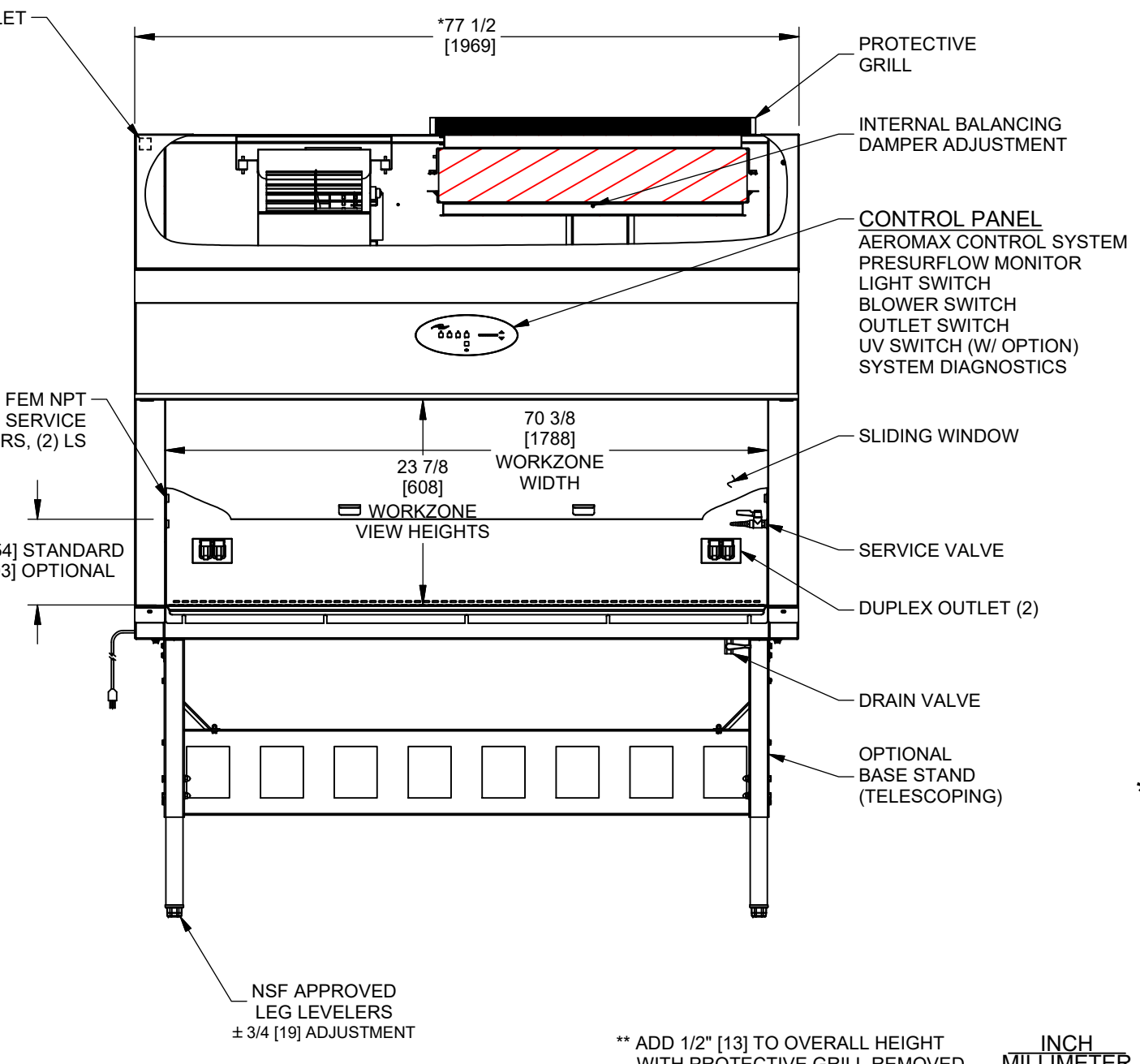
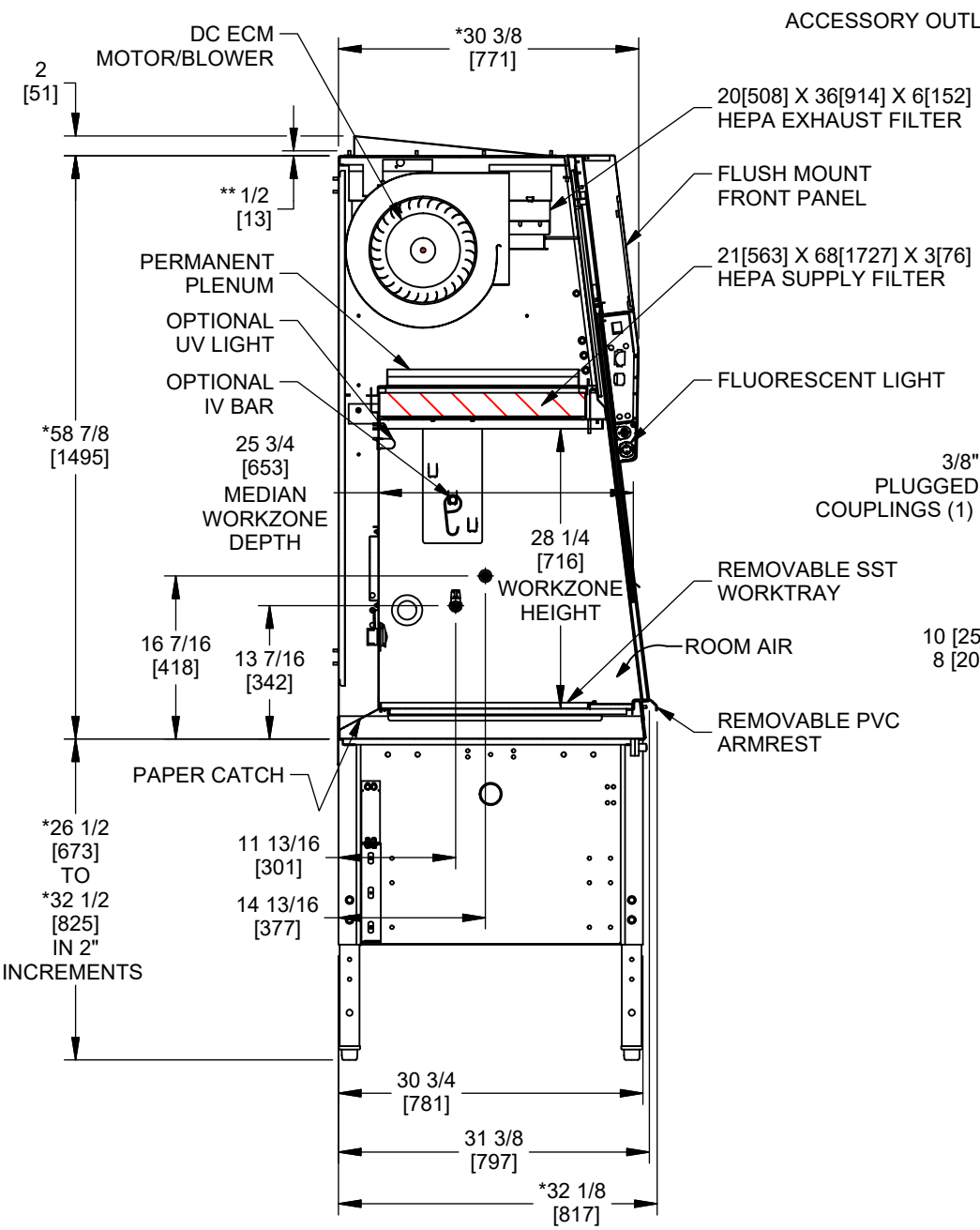
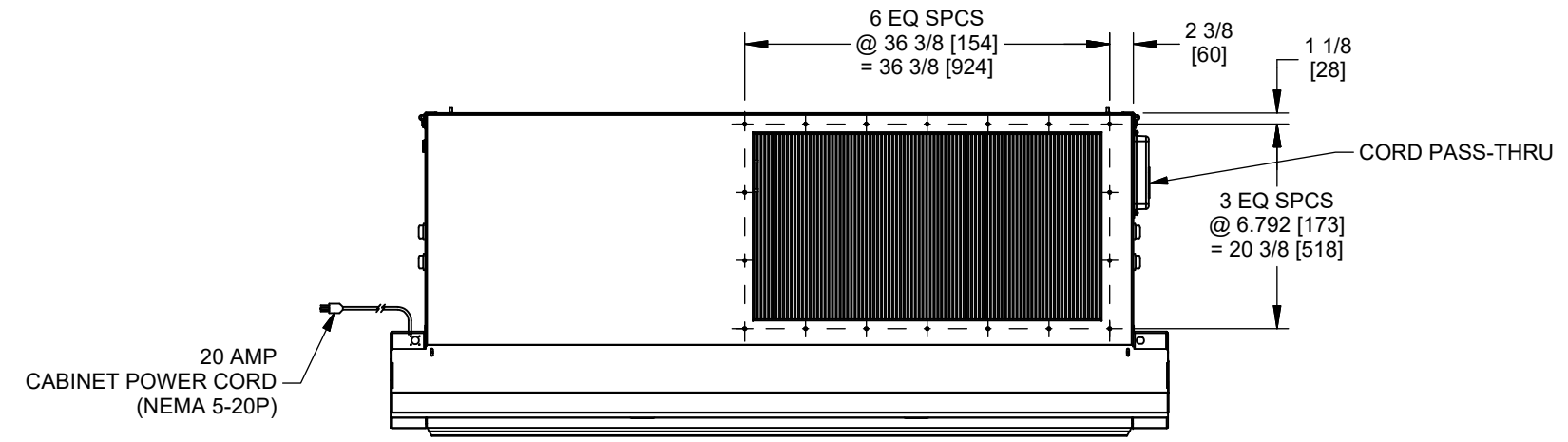

* OVERALL DIMENSIONAL TOLERANCE ±1/4 [6.35]
ALL OTHER DIMENSIONS ±1/8 [3.17]

TITLE NU-540-600 Class II, Type A2 Biosafety Cabinet					
DFTM LS	DATE 12/15/2013	CHKD BP	SHEET 1	OF 1	
DRAWING NUMBER BCD-16516			D		

** ADD 1/2" [13] TO OVERALL HEIGHT WITH PROTECTIVE GRILL REMOVED

INCH
MILLIMETER