



PURCHASE SPECIFICATIONS FOR NUAIRE PHARMAGARD™ NU-NR800 NEGATIVE PRESSURE RECIRCULATING STERILE ISOLATOR

The intent herein is to provide a concise statement of requirements for a quality negative pressure Sterile Products Compounding Isolator, which may be used to augment your purchase request/order.

The NU-NR800 meets the barrier isolator requirements of the USP 800, Pharmaceutical Compounding Sterile Preparations. The NU-NR800 also meets NIOSH and ASHP guidelines for hazardous drug preparations.

NuAire sales representatives will be pleased to explain the importance of the performance and control affected by each of the following requirements. The NuAire NU-NR800 meets all of the requirements in the following SPECIFICATION.

1. Dimensions Inches (mm)

Overall Dimensions	NU-NR800-400	NU-NR800-600
Width (W)	50 (1270)	74 (1880)
Depth (D)	32-1/2(826)	32-1/2(826)
Height (H)	51-3/4 (1314)	51-3/4 (1314)
(Incl. Exhaust Grill)		
(minimum w/optional adjustable basestand)	81-3/4 (2076)	81-3/4 (2076)
 <u>Workzone</u>		
Interior Dimensions		
Width (W)	35-1/4 (895)	59-1/4 (1505)
Depth (D)(center of glove port)	23-1/4 (591)	23-1/4 (591)
Height (H)	27-3/8 (695)	27-3/8 (695)
 <u>Interchange</u>		
Interior Dimensions		
Width (W)	14-1/8 (359)	14-1/8 (359)
Depth (D) (at worksurface)	24 (610)	24 (610)
Height (H)	27-3/8 (695)	27-3/8 (695)

2.* Cabinet shall provide performance as specified.

- a. Cabinet shall maintain a negative pressure within the workzone and slightly more negative pressure in the interchange to assure preparation and transfer containment and sterility.
- b. Cabinet shall provide better than ISO Class 5 (Federal Standard 209E Class 100) within workzone and interchange.
- c. Supply HEPA filter shall be the full length of the cabinet workzone providing better than ISO Class 5 laminar downflow designed to eliminate cross contamination on the worksurface.
- d. Supply HEPA filter shall be protected by perforated metal diffusers covering the entire top of both workzone and interchange.

- 3.* The cabinet shall be ergonomically designed for maximum user comfort and process efficiency.
 - a. Cabinet shall have a centrally located instrument panel within the control center that is easily serviced with quick disconnects.
 - b. Cabinet shall have the capability of incorporating a user adjustable base stand as an option.
 - c. Cabinet shall have a hinged lockable window slanted 10° from vertical for optimal work with glove ports.
 - d. The hinged lockable window shall allow full access to entire workzone and interchange.
 - e. Cabinet shall have (2) independent work trays for workzone and interchange being removable with coved corners for easy cleaning.
 - f. Cabinet shall have large exterior hinged transfer door 8-1/2" x 18" (235 x 457mm) minimum for efficient product movement in and out of the transfer chamber.
 - g. Cabinet shall have large interior sliding door 8-1/2" x 18-1/2" (216 x 470mm) minimum for efficient product movement in and out of the workzone.

- 4.* The cabinet shall have all filter positive pressure plenums surrounded by a vacuum relative to the room.

5. Electrical power shall be supplied with a 12-foot (2.5m), 3-wire cord with hospital grade plug.
Electrical supply should be 115VAC, 60Hz protected with thermal circuit breaker from distribution panel.

6. The cabinet shall use a DC EC Impeller optimally determined for each model size/width to maximize both energy efficiency and filter loading capacity.

- 7.* The cabinet shall have two internal electrical circuits; one for blower/lights and one for the hospital grade duplex outlet.
Each circuit shall be protected with a fuse located in the Control Center.

8. The cabinet shall be listed by Underwriters Laboratories to meet the requirements of both the U.S. and Canada for electrical/mechanical integrity.

- 9.* Cabinet shall contain a FlowGard™ control system consisting of electronic modules that will perform the following functions:
 - Easy user interface via OLED (Organic Light Emitting Diode) display/function keys.
 - Language selectable user interface menu's (English, Spanish, German, French, Chinese, Japanese)
 - Control blower via solid state switch.
 - Control lights via solid state switch.
 - Control outlets via solid state switch.
 - Disable audible alarm switch with ring back function.
 - Control blower DC EC motor with solid-state DC Motor Controller that provides automatic compensation (constant volume control) for line voltage variances.

- 10.* Cabinet shall contain the FlowGard™ control system that provides the following optional functional features (included with cabinet, but must be configured during certification):
 - Security password protection of cabinet use.
 - Cabinet usage displays filter life, blower hours and UV light hours.
 - Cabinet usage sync functions with blower, fluorescent light, outlets and accessory outlet.
 - Cabinet usage auto duration timers, fluorescent light, UV light and outlets.

11. Balancing of cabinet negative pressure shall be accomplished with integrated HEPA filter/blower assembly controlled via solid-state motor voltage regulator with exhaust interlock system that prevents workzone and interchange to be positively pressured.

12. The cabinet shall be easily transportable through a standard 36-inch (914mm) wide door without disassembly.

13. Fluorescent lighting shall be externally mounted and provide a minimum of 40 (430) foot-candles (LUX) on work surface.
The ballast is to be electronic containing thermal protection with automatic reset.

14. Cabinet shall have two minihelic gauges to display negative pressure of workzone and interchange area.

15. Cabinet shall come standard with one hospital grade duplex with drip proof cover on back wall.
- 16.*Cabinet shall be easily bench mounted or freestanding console model with the addition of the optional bench mount support or various basestand options.
17. Cabinet workzone shall be all 16 GA.
18. Cabinet shall have a large removable workzone worktray with integral hinged support rods to be raised and held up for cleaning.
- 19.*Cabinet shall have a permanent positive pressure plenum with quick release supply filter removal.
- 20.*Cabinet shall be capable of front/top filter removal without disassembly of the control panel and hinged window hardware.
21. Cabinet interchange doors shall be interlocked to prevent the inner door from opening when the outer door is open.
22. Cabinet shall have a three-position IV bar with 6 hooks.
23. Cabinet exhaust requirement shall be the following used with canopy connections:

NU-NR800-400
200 CFM @ 0.1" w.g.

NU-NR800-600
225 CFM @ 0.1" w.g.

24. The following optional equipment shall be available to support installation and user requirements:

- Hospital Grade Ground Fault Interrupter for Electrical System
- Additional Service Valves for Gas, Air, Vacuum
- Additional Hospital Grade Duplex
- Bench Mount Support
- Telescoping Base Support Stand
- Storage Pullout Trays
- Pull Out Shelf
- Cord Pass-Through
- Adjustable Automatic Base Support Stand with Leg Levelers
- Sharps/Sharps (Large) Disposal System for Hazardous Drugs
- Gas Tight Damper
- Flex Duct Kits
- Custom Options Available

*Having all of these features is unique ONLY to NuAire cabinets.

**Pharmagard™ Negative Pressure
Recirculating Sterile Isolator
Models NU-NR800-400/600**

Catalog Number	Catalog Number	
	NU-NR800-400 Nominal 4 foot (1.2m)	NU-NR800-600 Nominal 6 foot (1.8m)
Performance Specifications	CETA CAG-002-2006	CETA CAG-002-2006
1. Product Protection	ISO Class 5 (Laminar Flow)	ISO Class 5 (Laminar Flow)
Style of Isolator	Bench top/console Isolator	Bench top/console Isolator
Isolator Construction	Welded stainless steel 16GA, Type 304 pressure tight design	Welded stainless steel 16GA, Type 304 pressure tight design
Interchange Chamber	ISO Class 5 With Internal/External Sealed Doors	ISO Class 5 With Internal/External Sealed Doors
Diffuser for Air Supply (Metal)	Non-flammable	Non-flammable
HEPA Filter Seal Type: Supply Filter-99.99% Eff. on 0.3 microns Exhaust Filter-99.99% Eff. on 0.3 microns	Neoprene, Spring loaded Under Negative Pressure	Neoprene, Spring loaded Under Negative Pressure
Standard Services: Hospital Grade Duplex Outlet	One, Backwall	One, Backwall
Optional Services: Service Valves 3/8" NPT	Up to 3	Up to 3
Isolator Size Inches (mm): Height Height (Minimum w/opt. Adjustable Base Stand) Width Depth (with Control Center)	51 3/4 (1314) 81 3/4 (2076) 50 (1270) 32 1/2 (826)	51 3/4 (1314) 81 3/4 (2076) 74 (1880) 32 1/2 (826)
Work Zone Inches (mm): Width Height Depth (Center of Glove Port)	35 1/4 (895) 27 3/8 (695) 23 1/4 (591)	59 1/4 (1505) 27 3/8 (695) 23 1/4 (591)
Interchange Inches (mm) Width Depth (at Work Surface) Height	14 1/8 (359) 24 (610) 27 3/8 (695)	14 1/8 (359) 24 (610) 27 3/8 (695)
Hinged Lockable Viewing Window (Polycarbonate)	Fully closed to fully open	Fully closed to fully open
Exhaust CFM/CMH Standard/Optional: Canopy NU-916-797	200/340	225/382
Plan Duct Static Pressure Eng./Metric: (water gauge)	0.05-0.1"/1.24-2.54 mm	0.05-0.1"/1.27-2.54 mm
Heat Rejected, BTU, Per Hour	795	1136
Electrical: Volts, AC 60 Hz Amps: Blower/Lights Amps: Hospital Grade Duplex Amps: Total 12 ft. Hospital Grade Power Cord (one)	UL/UL-C Listed 115 3 3 6 14 GA - 3 Wire, 15A	UL/UL-C Listed 115 5 3 8 14 GA - 3 Wire, 15A
*Crated Shipping Weight: *Net Weight: Net Optional Adjustable Automatic Base Stand Weight: Net Optional Telescoping Base Stand Weight: Net Optional Bench Mount Weight:	490 lbs. /222 kg. 440 lbs. /200 kg. 150 lbs. /68 kg. 60 lbs. /27 kg. 20 lbs. /19 kg.	640 lbs. /290 kg. 590 lbs. /268 kg. 160 lbs. /73 kg. 70 lbs. /32 kg. 20 lbs. /19 kg.

* For total weight, must select and add (1) of (3) base options.

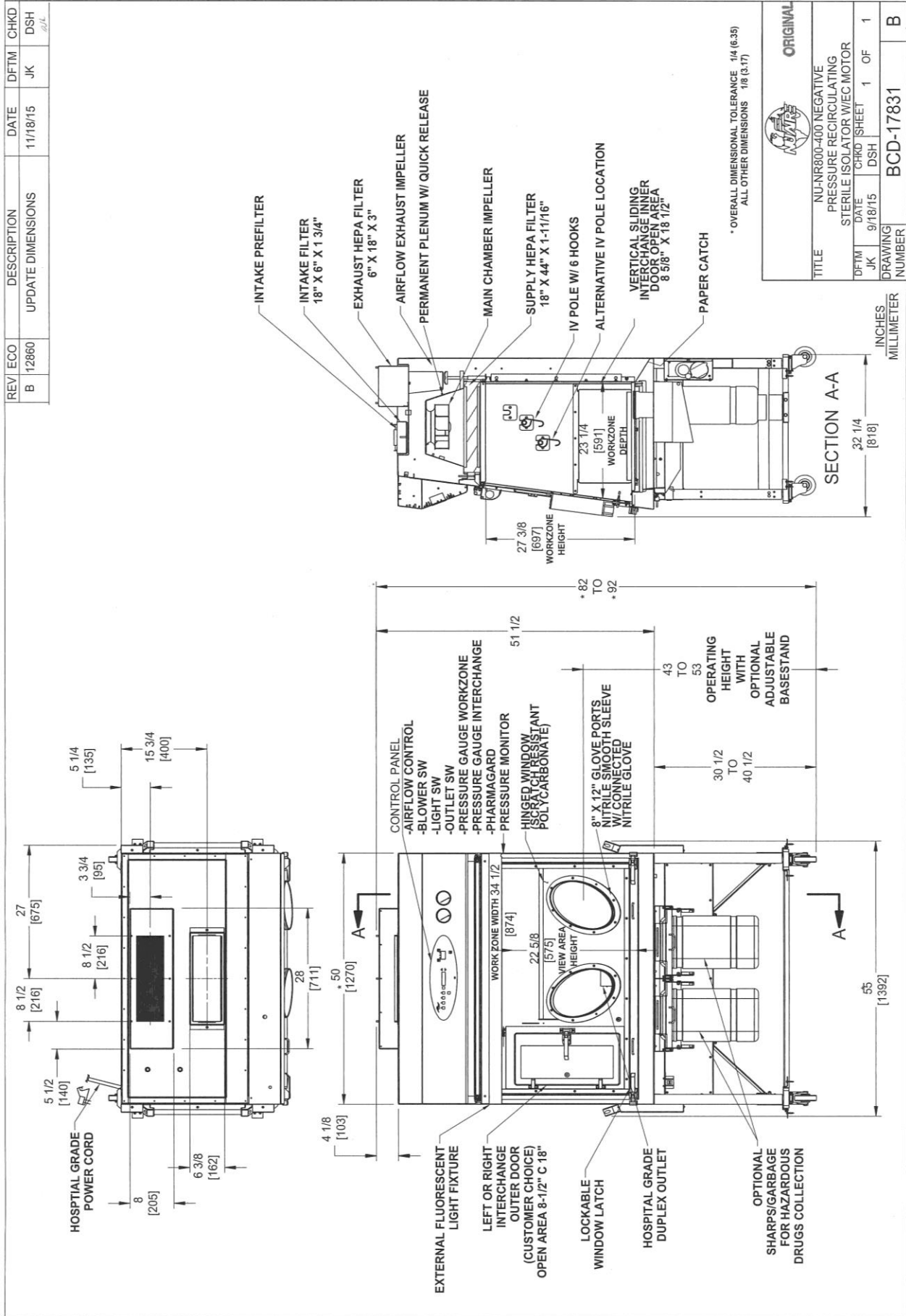

REV	ECO	DESCRIPTION	DATE	DFTM	CHKD
B	12860	UPDATE DIMENSIONS	11/18/15	JK	DSH

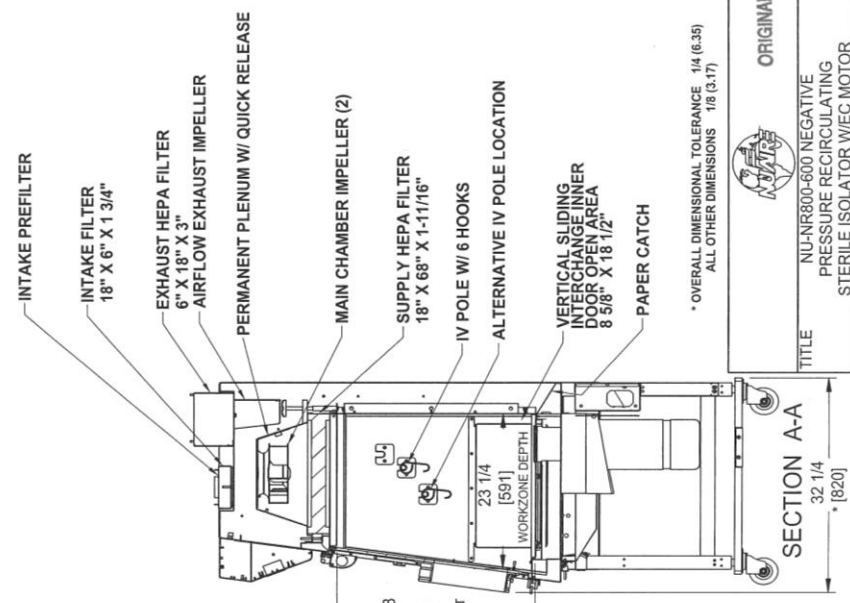
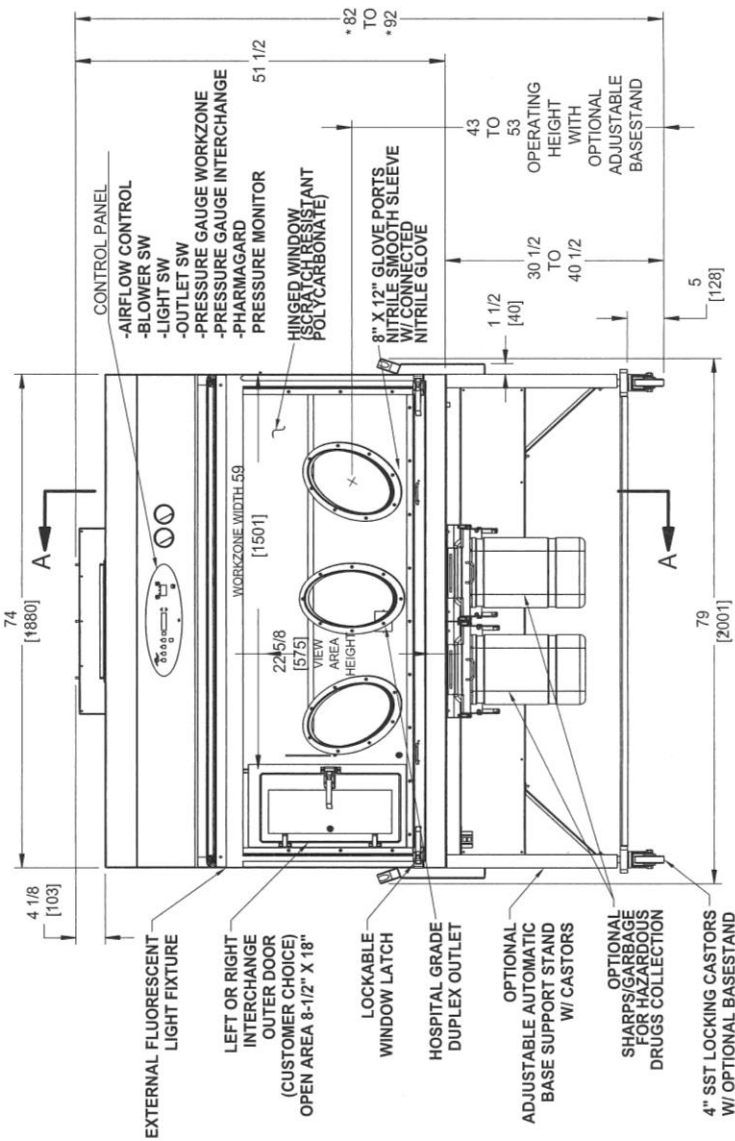
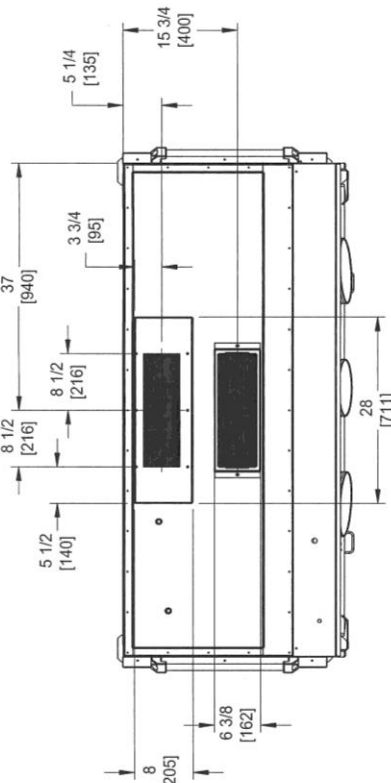

- INTAKE PREFILTER
- INTAKE FILTER 18" X 6" X 1 3/4"
- EXHAUST HEPA FILTER 6" X 18" X 3" AIRFLOW EXHAUST IMPELLER
- PERMANENT PLENUM W/ QUICK RELEASE
- MAIN CHAMBER IMPELLER (2)
- SUPPLY HEPA FILTER 18" X 68" X 1-11/16"
- IV POLE W/ 6 HOOKS
- ALTERNATIVE IV POLE LOCATION
- VERTICAL SLIDING INTERCHANGE INNER 8 3/8" X 18 1/2"
- PAPER CATCH

		ORIGINAL
TITLE NU-NR800-600 NEGATIVE PRESSURE RECIRCULATING STERILE ISOLATOR W/EC MOTOR		
DFTM	DATE	CHKD SHEET 1 OF 1
JK	9/18/15	DSH
DRAWING NUMBER		BCD-17832
INCHES		B
MILLIMETER		

* OVERALL DIMENSIONAL TOLERANCE 1/4 (6.35)
ALL OTHER DIMENSIONS 1/8 (3.17)