

REV	CO	DESCRIPTION	DATE	DFTR	CHKD
A	002417	RELEASED TO PRODUCTION	09/12/2023	RN	DF

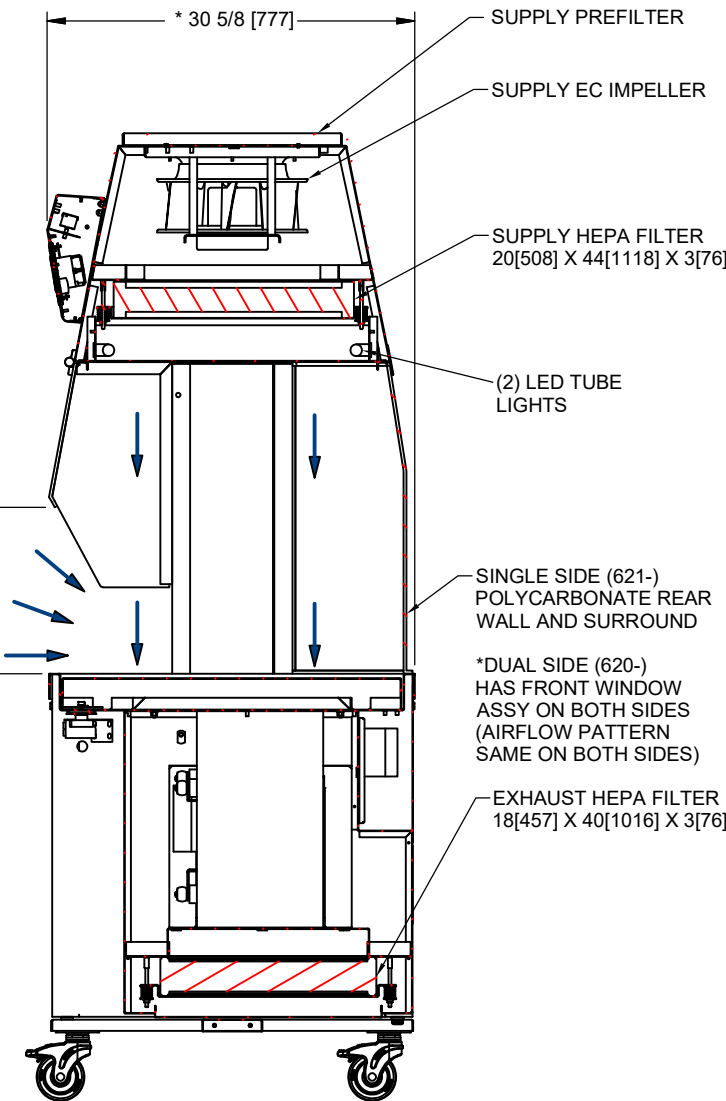

NOTE: THIS CABINET CONTAINS ELECTRONIC COMPONENTS THAT MAY CAUSE SOME GROUND FAULT CIRCUIT INTERRUPTER (GFCI) DEVICES TO INADVERTENTLY TRIP DUE TO INHERENT DESIGN DIFFERENCES. USE AT YOUR OWN RISK.

* OVERALL DIMENSIONAL TOLERANCE ±1/4 [6.35]
ALL OTHER DIMENSIONS ±1/8 [3.17]

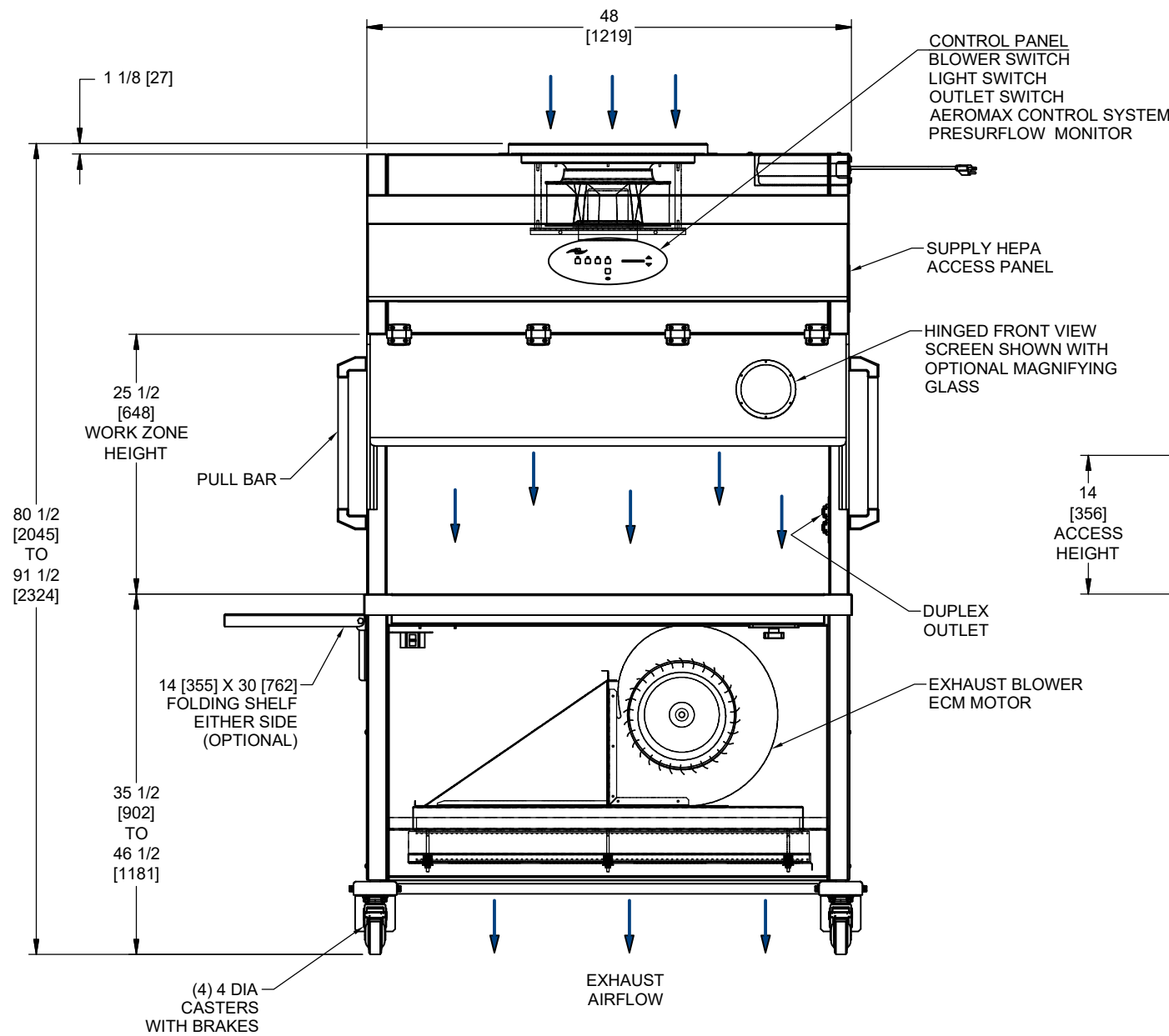
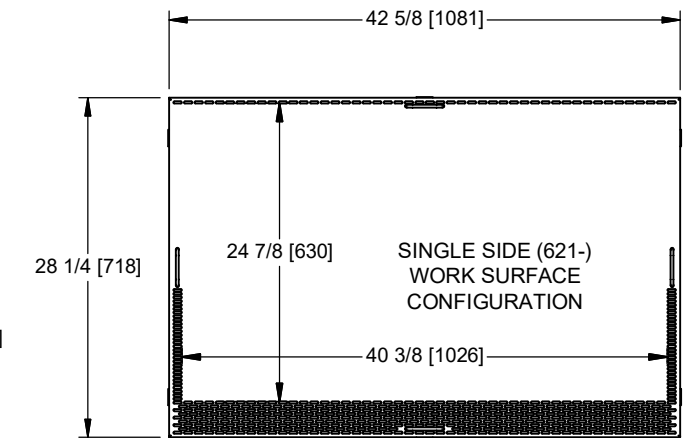
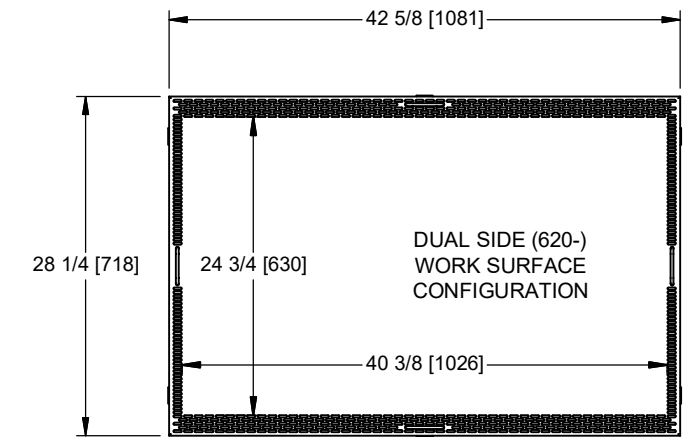
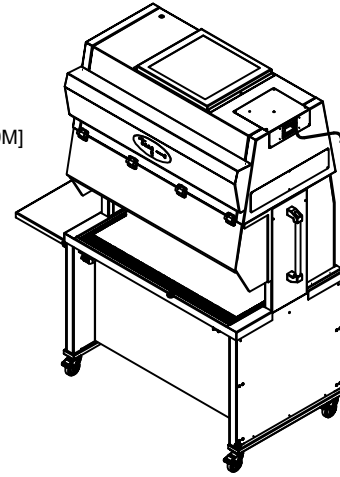
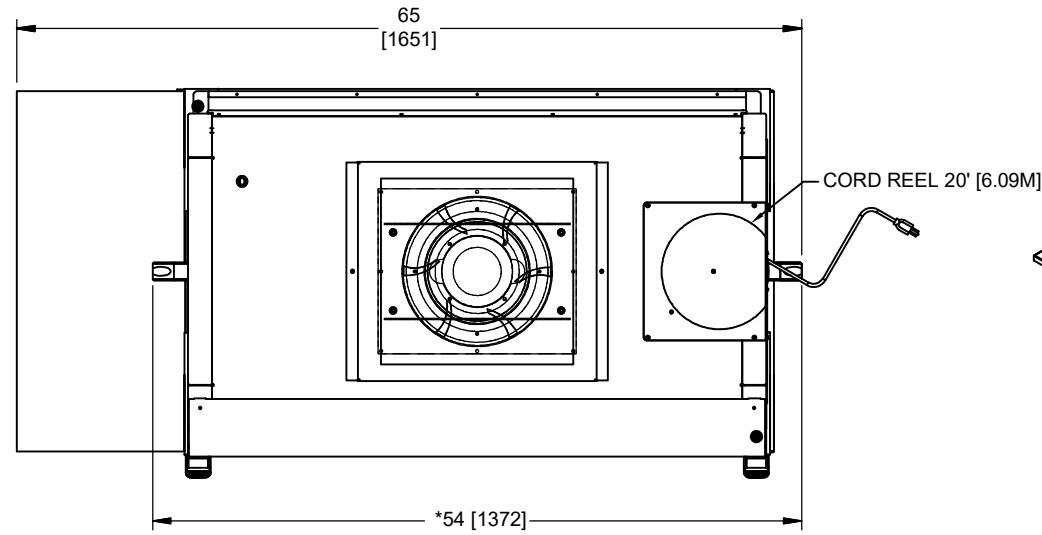

TITLE
NU-620/621-400 SPECIFICATION DRAWING

DFTR	RN	DATE	8/29/2023	CHKD	DF	SHEET	1	OF	1
DRAWING NUMBER		CD-000175						A	

INCH
MILLIMETER