

REV	CO	DESCRIPTION	DATE	DFTR	CHKD
A	001199	RELEASED	11/17/2022	RN	DF

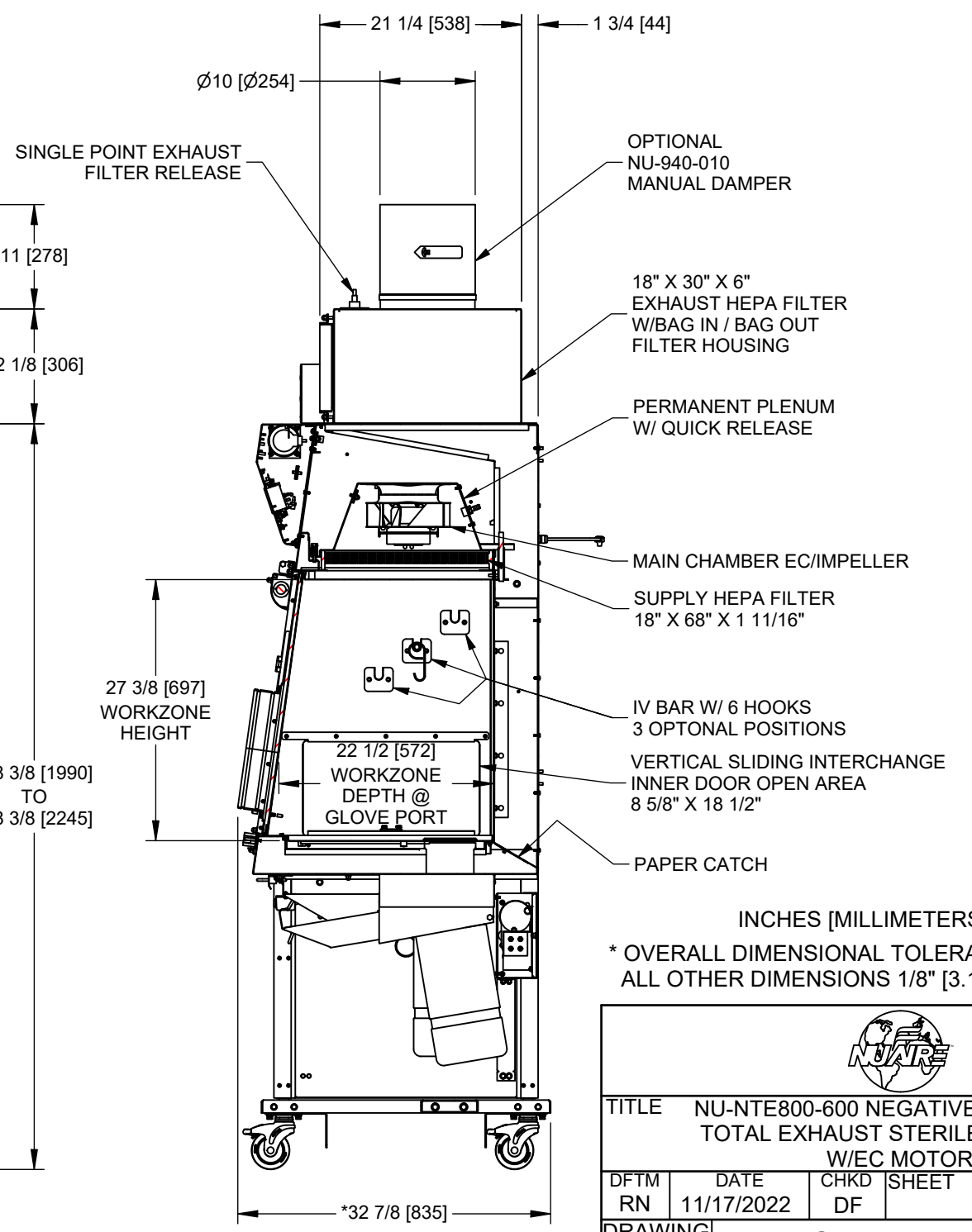
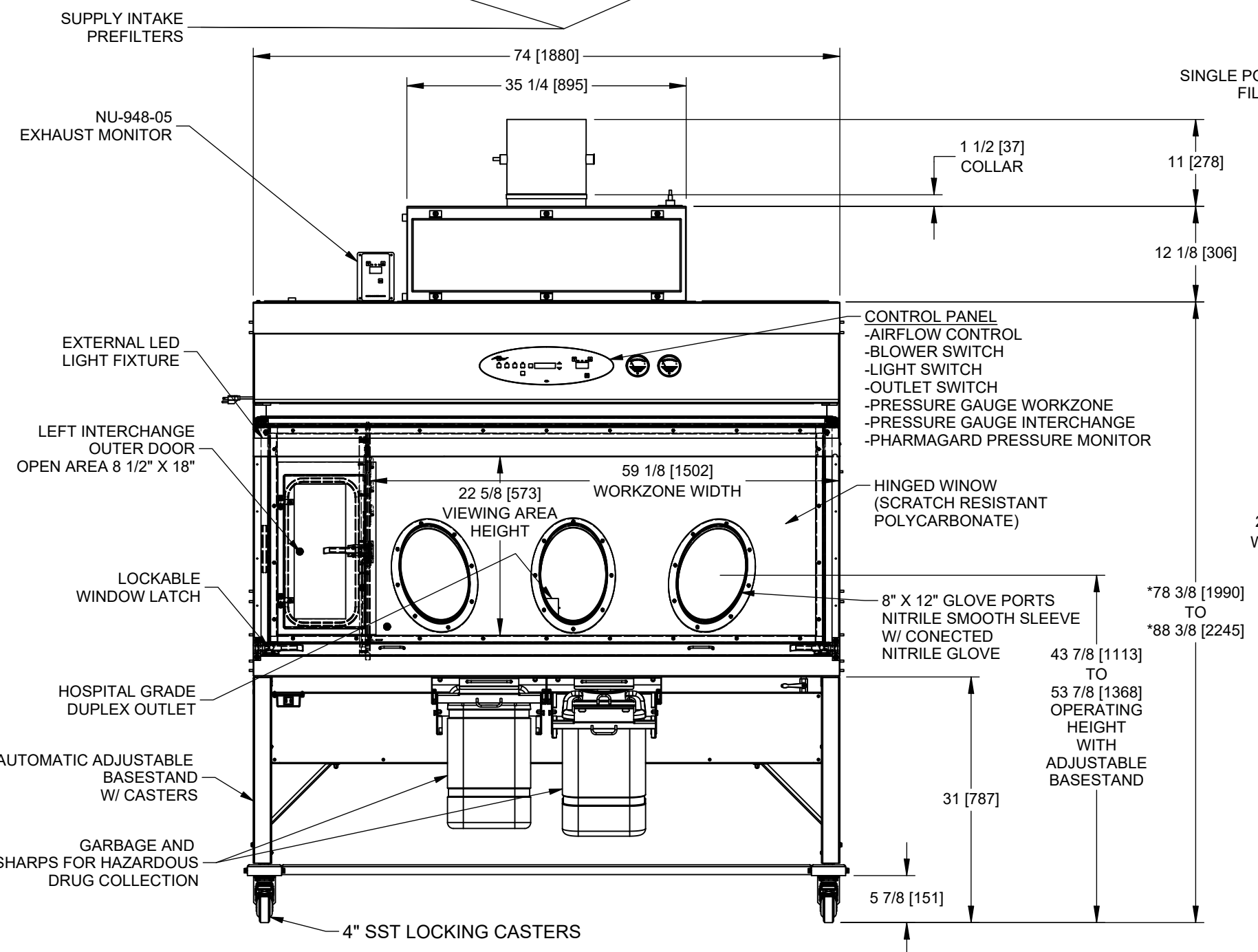
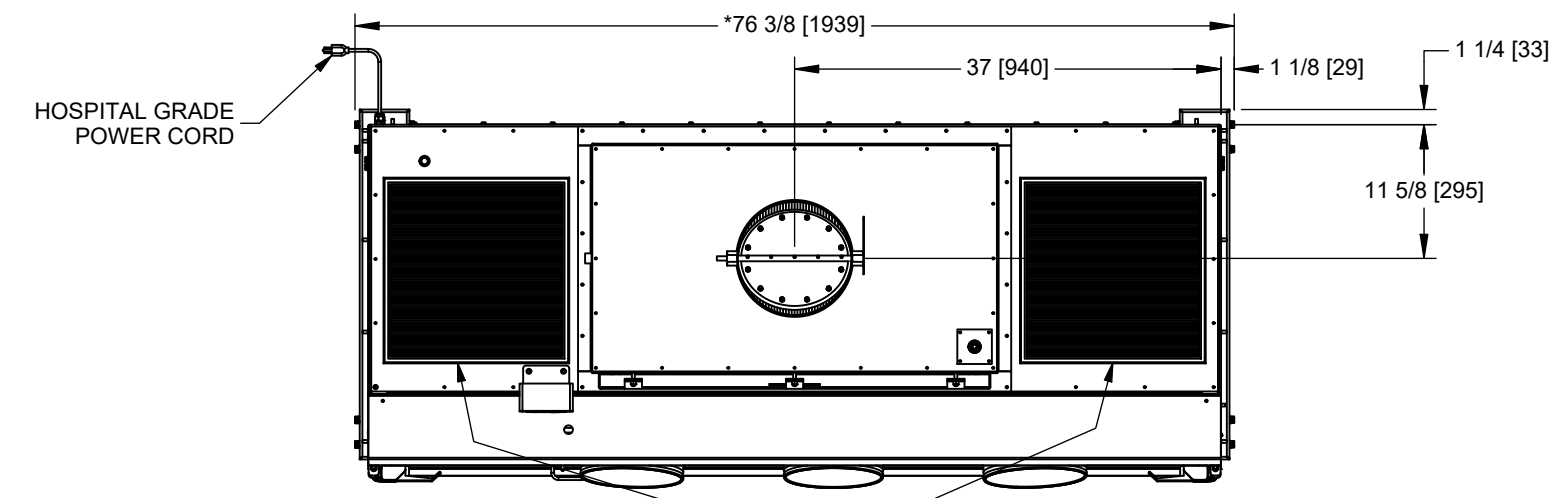

INCHES [MILLIMETERS]
 * OVERALL DIMENSIONAL TOLERANCE ±1/4" [6.35]
 ALL OTHER DIMENSIONS 1/8" [3.17]

TITLE NU-NTE800-600 NEGATIVE PRESSURE TOTAL EXHAUST STERILE ISOLATOR W/EC MOTOR					
DFTM RN	DATE 11/17/2022	CHKD DF	SHEET 1	OF 1	
DRAWING NUMBER		CD-000145		A	

REF: BCD-20318