

REV	CO	DESCRIPTION	DATE	DFTM	CHKD
E	000631	UPDATED W/ STANDARD PROP-UP WORKTRAY AND LED LIGHTING	2/22/2021	TH	DSH

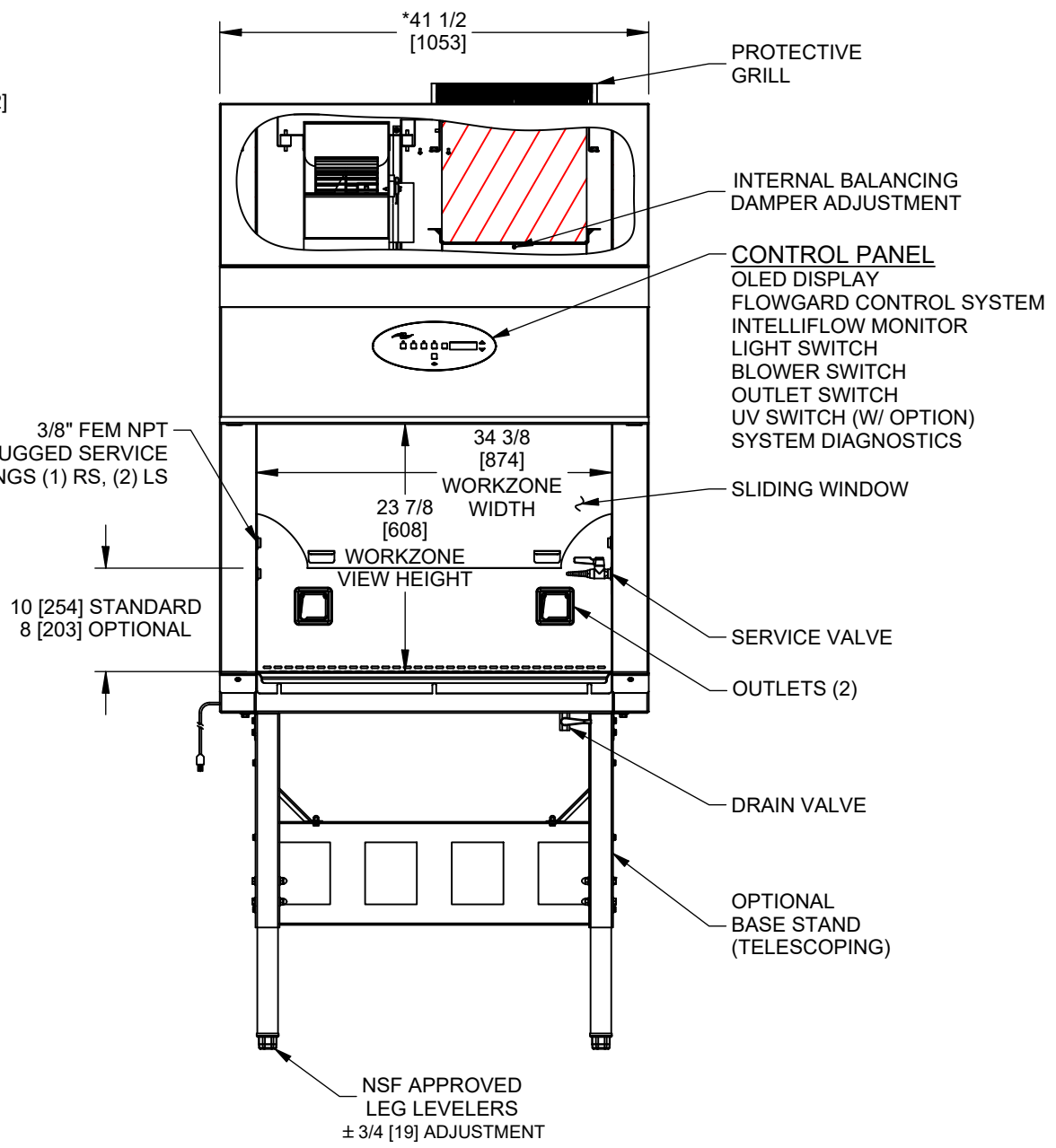
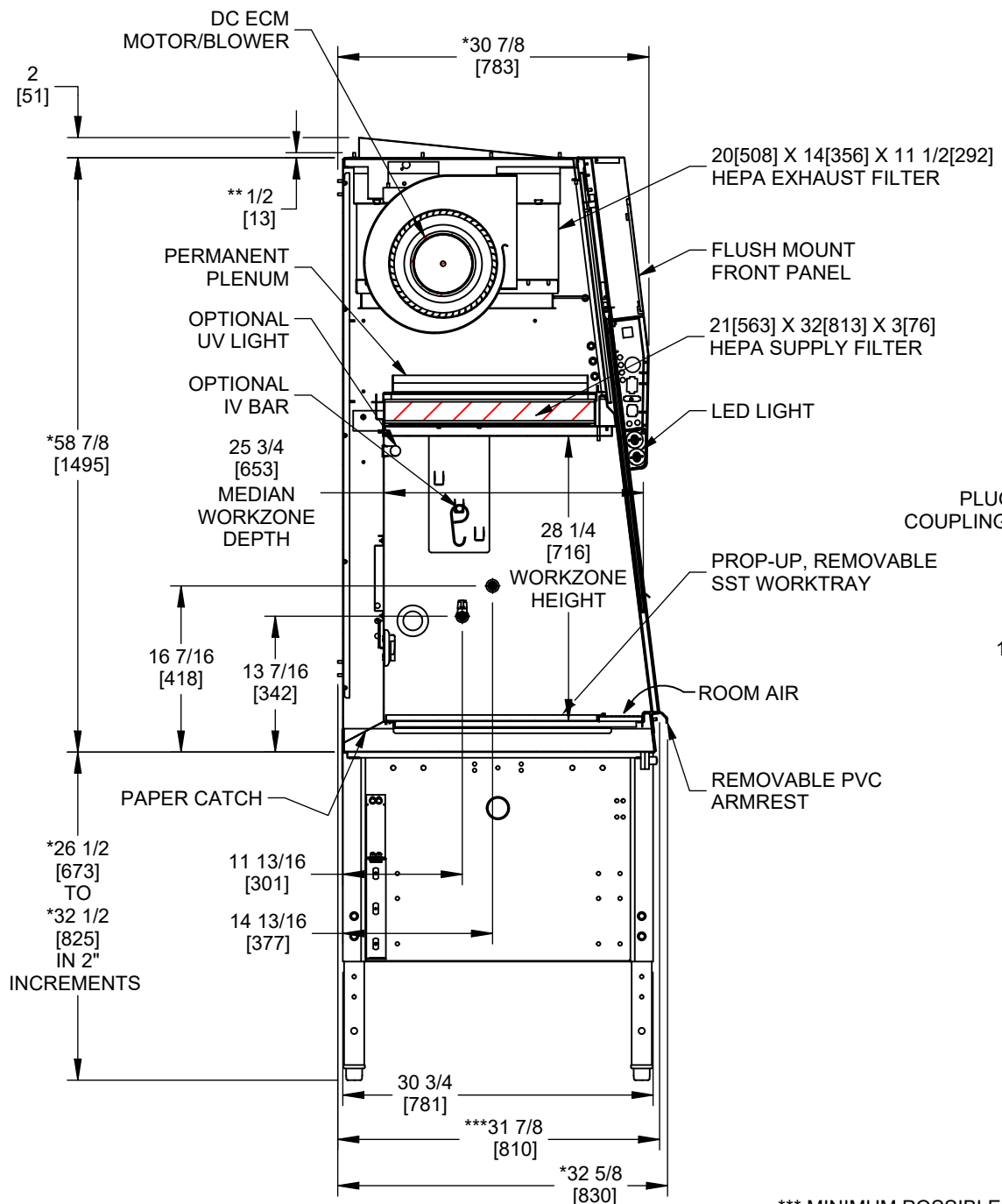
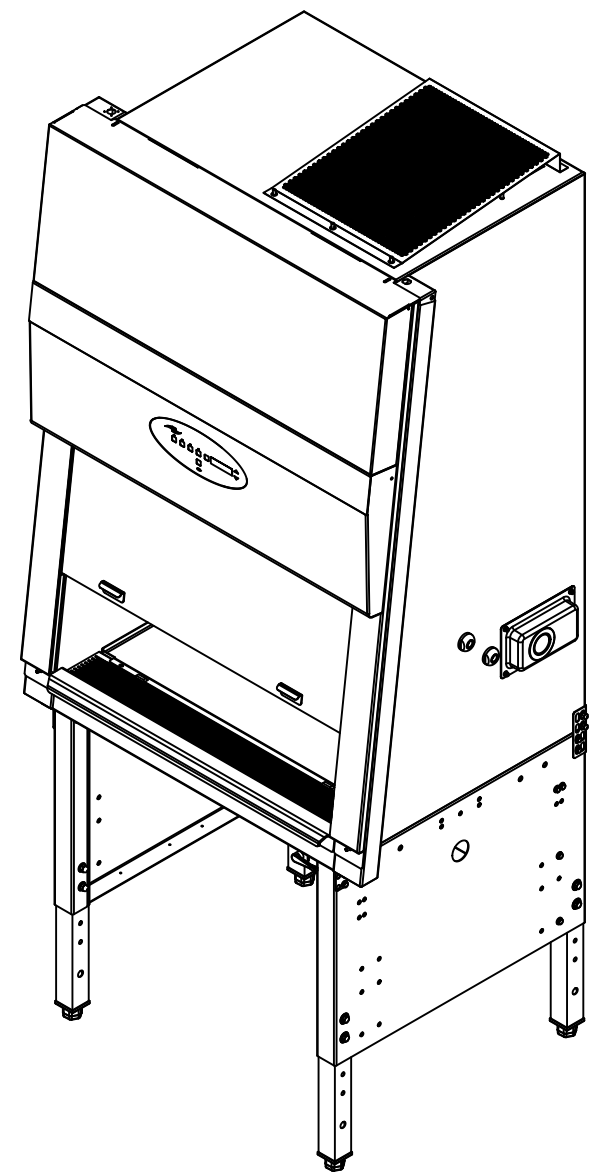
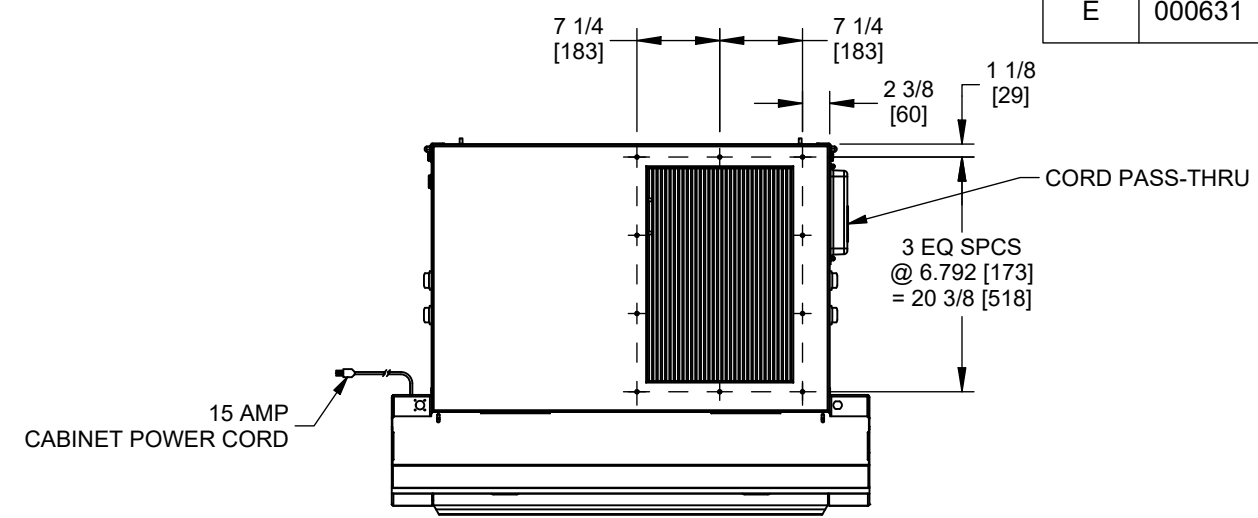

*** MINIMUM POSSIBLE DEPTH OF BSC

** ADD 1/2" [13] TO OVERALL HEIGHT WITH PROTECTIVE GRILL REMOVED

INCH MILLIMETER

* OVERALL DIMENSIONAL TOLERANCE ±1/4 [6.35]
ALL OTHER DIMENSIONS ±1/8 [3.17]

TITLE NU-543-300E Class II Biosafety Cabinet				
DFTM LS	DATE 5/19/2014	CHKD BP	SHEET 1	OF 1
DRAWING NUMBER BCD-16883		E		