

Parts List						REV	ECO	DESCRIPTION	DATE	DFTM	CHKD	
ITEM	QTY	PART NUMBER	3 FT.	4 FT.	6 FT.	DESCRIPTION	H	13580	UPDATED HARDWARE	12/29/2017	TH	DSH
1	2	A-425-7373				BRACE LATERAL, BSC						
2	8	A-500-395				BUSHING, BASE STAND LEG						
3	2	B-400-9562				WELDMENT, END PANEL, BASESTAND (28")						
4	1	B-500-391-TAB	-01	-02	-04	WELDMENT, CROSS MEMBER PANEL 3 FT.						
5	4	B-500-507				WELDMENT, LEG EXTENSION (CASTOR)						
6	4	B-620-2285				BASESTAND, SAFETY ANGLE FOR 4 INCH CASTER						
7	*4	B-800-1577				WELDMENT, LEG EXTENSION (CASTOR) EXTENDED HEIGHT						
8	1	B-813-1510-01				BRACKET, 813 BASE STAND, FRONT LEFT						
9	1	B-813-1510-02				BRACKET, 813 BASE STAND FRONT RIGHT						
10	1	B-813-1511-01				BRACKET, 813 BASE STAND, REAR LEFT						
11	1	B-813-1511-02				BRACKET, 813 BASE STAND, REAR RIGHT						
12	4	X-980040-08				CASTOR, SWIVEL W/ BRACKET, 4" . SST						
13	16	X-980490-06				NUT HEX 5/16 - 18, FINISHED, SST						
14	8	X-980493				ACORN NUT, 1/4-20						
15	8	X-980494-03				NUT, ACORN 3/8-16 18-8 SST						
16	8	X-980495				1/4-20 NUTSERT						
17	12	X-980604-02				BOLT, G2, 1/4-20 X .75 LG						
18	4	X-980609-06				SCR PPH 8-32 X 1-1/4 SST						
19	8	X-980659-03				SCREW, HHCS, 1/4-20 X 1/2 18-8 SST						
20	16	X-980667-01				5/16-18 X 3/4 BOLT						
21	8	X-980781-07				3/8 LOCK WASHER						
22	4	X-980783-03				#8 SST FLAT WASHER						
23	8	X-980783-07				3/8 SST FLAT WASHER						
24	32	X-980790-06				WASHER FL 5/16 SAE SST						
25	28	X-980794-02				1/4 SST FLAT WASHER						
26	16	X-980795-05				WASHER LK 5/16" SPLIT 18-8 SST						
27	20	X-980815-01				1/4 INTERNAL TOOTH LOCK WASHER						
28	8	X-980929-01				BOLT 3/8-16 X 2-3/4 SST						

* EXTENDED HEIGHT OPTION

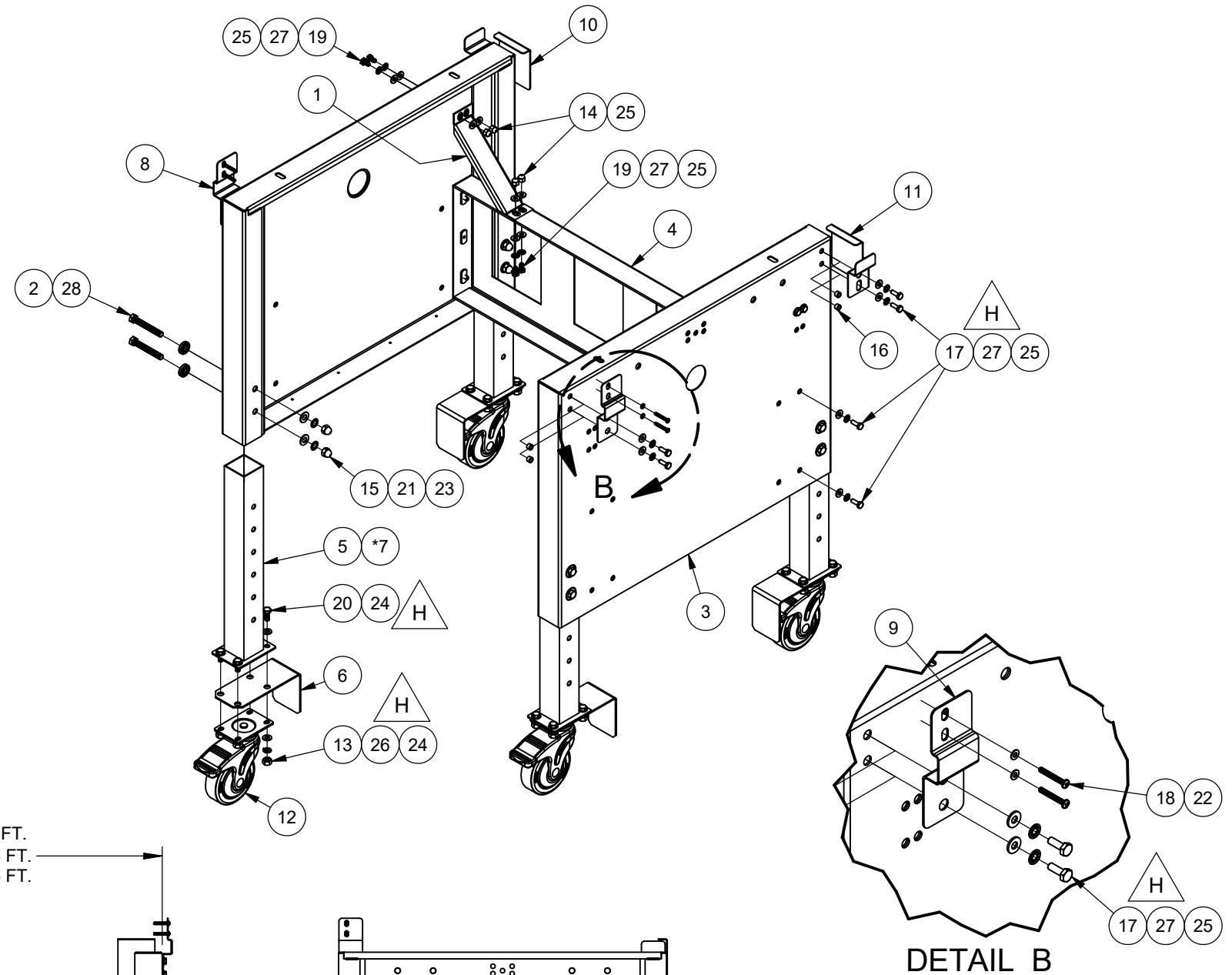
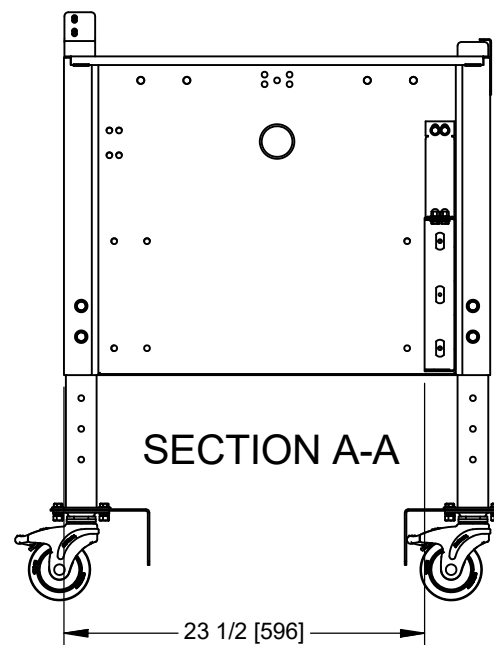
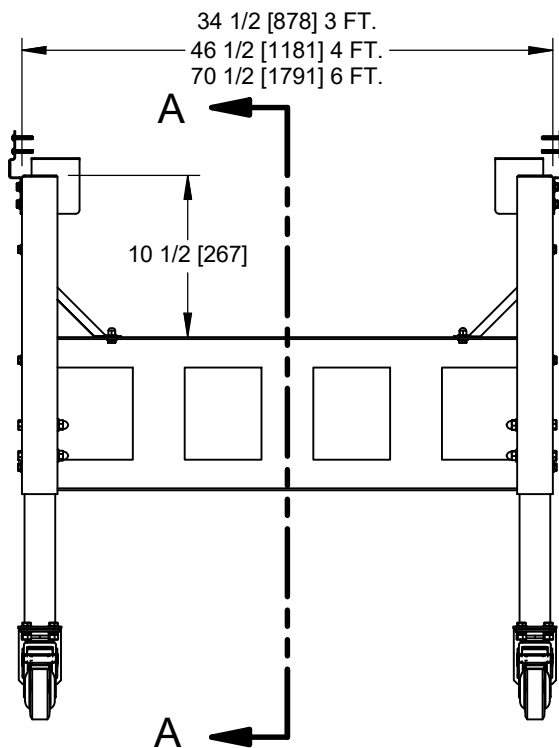
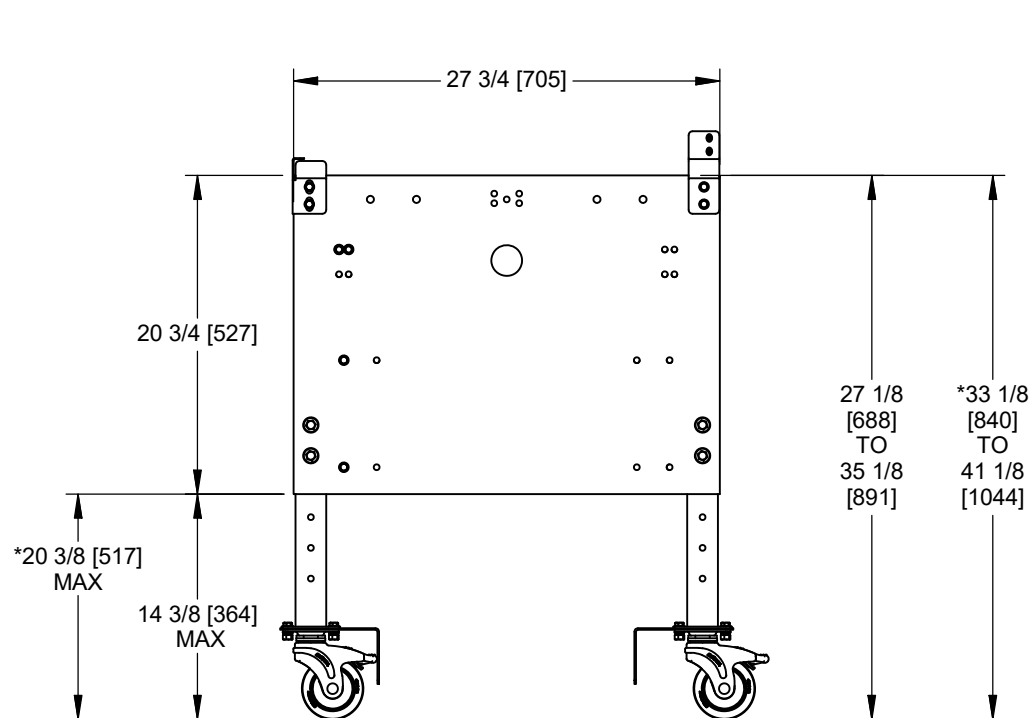

H
NU-813
NU-800-131
NU-800-132
NU-800-133
NU-800-143
NU-800-144
NU-800-145

TITLE ASSEMBLY, 28" BASESTAND TELESCOPING W/ CASTER			
DFTM IW	DATE 4/13/2015	CHKD MSS	SHEET 1 OF 1
DRAWING NUMBER BCD-17401			H